

POWER-LOCK EF SERIES INSTRUCTION MANUAL

NOTICE FOR SAFETY

- Read this instruction manual and other attached documents thoroughly before installing and using the POWER-LOCK.
 - Use the POWER-LOCK only after having full knowledge of the equipment and all applicable safety procedures.
 - Keep this instruction manual where the user can always refer to it.
- Safety precautions in this manual are classified into two categories: "WARNING" and "CAUTION". These are defined as follows:

⚠ WARNING: Death or serious injury may result if the POWER-LOCK is installed incorrectly.

⚠ CAUTION: Injury or physical damage may result if the POWER-LOCK is installed incorrectly.

Failure to follow the instructions under **⚠ CAUTION** may also result in death or serious injury depending on the particular situation.

⚠ WARNING

(Overall)

- If the device is used on equipment for transporting people, install the appropriate protection devices to the transportation equipment to provide the required safety.
- If the device is used on elevation equipment, install the appropriate safety devices to the elevation equipment to prevent the falling of materials. The falling of materials may cause injury to personnel or damage to the equipment.
- Comply with all applicable safety standards of the country where the device is used. When revisions are published, those updated revisions shall apply.

⚠ CAUTION

(Delivery)

- Verify that you received exactly what you ordered. Use of the incorrect item may cause injury or equipment damage.

(Installation)

- Always use a torque wrench when installing the tightening bolts and adhere to the procedure and torque values listed in this instruction manual. If the bolts are tightened without the use of a torque wrench, the correct torque may not be obtained causing slippage or deformation of the POWER-LOCK and result in an accident.
- Never use oils containing silicone or molybdenum disulfide lubricants when lubricating the connecting surfaces (e.g. shaft or hub inner surface) for the POWER-LOCK.
- Only use the bolts that came with the POWER-LOCK. If bolts are missing or damaged, contact our sales office or our dealers from whom you purchased for replacement. Use of other bolts may result in breakage of the bolt and cause an accident.
- Never strike the POWER-LOCK with a hammer or other such tool when mounting the POWER-LOCK to the shaft and hub. Doing so may deform the POWER-LOCK and cause an accident.

(Removal)

- Always confirm that there are no torque or thrust loads on the hub or shaft before removing the POWER-LOCK. If torque or thrust loads are present, the POWER-LOCK may suddenly release and allow the device to spin or come off when the tightening bolts are loosened.
- Especially for elevator applications, never loosen the tightening bolts while a load is being held. Doing so may cause the load to drop.

(Repeated use)

- Completely inspect each part of the POWER-LOCK prior to reusing. If any damage is found, replace the unit.

Thank you for your purchase of the EF series POWER-LOCK.

The POWER-LOCK is a frictional, keyless shaft-hub locking device for connecting hubs and shafts subject to large torque variations. Fitting is simply made by tightening bolts after installing the POWER-LOCK between the shaft and hub. Since torque is transmitted by the contact pressure and friction between the surfaces in contact with the hub and shaft, the condition of the contact surfaces and proper tightening of the bolts are of great importance. Read first and then follow all of the instructions carefully so as to ensure satisfactory performance.

■ Installation

1. Clean the inner surface of the hub and surface of the shaft, and apply a slight amount of oil to both surfaces. (Never use lubricants containing silicone or molybdenum disulfide.)
2. Remove the tightening bolts from the POWER-LOCK and clean and slightly oil or grease them. Threads and seats of the tightening bolts must be sufficiently lubricated. (If the POWER-LOCK is not sufficiently lubricated at all locations, excess friction will result and prevent the specified torque from being obtained.)
3. Insert the POWER-LOCK into the hub and shaft and tighten the bolts by hand until a slight positive contact is obtained and bring them to desired position. (Never strike the POWER-LOCK with a hammer or other such tool during the mounting.)
4. Set a torque wrench to approximately 1/4 of the torque MA (refer to the table given below for torque MA) and tighten each of the tightening bolts evenly in the sequence shown in figure 3.

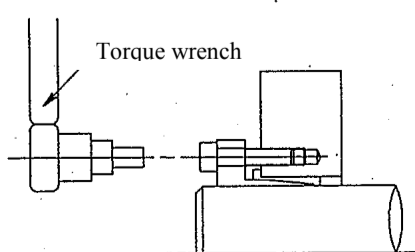

Fig. 2

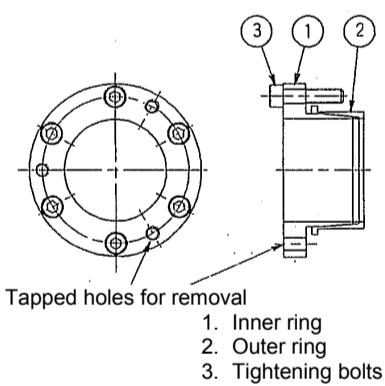

Fig. 1: Configuration

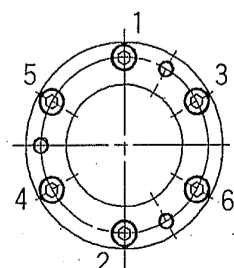

Fig. 3 Tightening sequence for bolts

5. Raise the torque wrench setting to 1/2 of the torque MA and repeat the procedure given in step 4 above.
6. Raise the torque wrench setting to the full torque MA and repeat the procedure given in step 4 above.
7. Finally confirm that all tightening bolts have been tightening to torque MA. To do this, moving clockwise across the bolts, tighten each one until none can be turned by a torque wrench set at MA.

Table 1 : Tightening bolt size and torque MA

| POWER-LOCK shaft dia. mm | Tightening bolt size | Tightening torque MA | |
|-----------------------------|-------------------------|----------------------|------------|
| | | N·m | {ft. lbs.} |
| 10 – 17 | M 4 | 4.0 | {2.95} |
| 18 – 35 | M 5 | 8.3 | {6.13} |
| 38 – 42 | M 6 | 13.7 | {10.1} |
| 45 – 80 | M 8 | 34.3 | {25.3} |
| 85 – 120 | M 10 | 67.6 | {49.9} |

■ Removal

1. Confirm that there is no torque or thrust loads on the hub or shaft. When the tightening bolts are loosened, the POWER-LOCK may suddenly release and allow the device to spin or come off. After ensuring safety, slowly loosen and remove the tightening bolts.
2. Remove hub and the POWER-LOCK from the shaft.
3. If the POWER-LOCK still locks even after loosening bolts, tighten bolts into the tapped holes for removal. (see Fig.4)

Hex socket
Screw keys

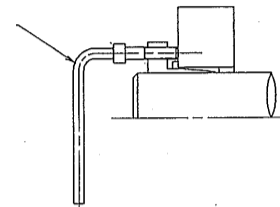

Fig. 4 Removal



Important

1. Never use lubricants containing silicone or molybdenum disulfide.
2. When installing the tightening bolts, always use a torque wrench.
3. Do not use any bolts other than the bolts that were supplied with the POWER-LOCK. (The bolts required for the POWER-LOCK are special bolts of a high tensile strength and only those supplied with the POWER-LOCK should be used.)

■ Warranty

TSUBAKIMOTO CHAIN CO.: hereinafter referred to as "Seller"

Customer: hereinafter referred to as "Buyer"

Goods sold or supplied by Seller to Buyer: hereinafter referred to as "Goods"

1. Warranty period without charge
Effective 18 months from the date of shipment or 12 months from the first use of Goods, including installation of Goods to Buyer's equipment or machines - whichever comes first.
2. Warranty coverage
Should any damage or problems with the Goods arise within the warranty period, given that the Goods were operated and maintained according to the instructions provided in the manual, Seller will repair and replace at no charge once the Goods are returned to the Seller. This warranty does not include the following:
 - 1) Any costs related to removal of Goods from the Buyer's equipment or machine to repair or replace parts.
 - 2) Costs to transport Buyer's equipment or machines to the Buyer's repair shop.
 - 3) Costs to reimburse any profit loss due to any repair or damage and consequential losses caused by the Buyer.
3. Warranty with charge
Seller will charge a fee for any investigation and repair of Goods caused by:
 - 1) Improper installation due to not properly following the procedures in the instruction manual.
 - 2) Insufficient maintenance or improper operation by the Buyer.
 - 3) Incorrect installation of Goods to other equipment or machines.
 - 4) Any modifications or alterations of Goods by the Buyer.
 - 5) Any repair by engineers other than the Seller or those designated by the Seller.
 - 6) Operation in an inappropriate environment not specified in the manual.
 - 7) Force Majeure or forces beyond the Seller's control such as natural disasters and injustices committed by a third party.
 - 8) Secondary damage or problems incurred by the Buyer's equipment or machines.
 - 9) Defective parts supplied, or specified by the Buyer.
 - 10) Incorrect wiring or parameter setting by the Buyer.
 - 11) The end of life cycle of the Goods under normal usage.
 - 12) Loss or damage not liable to the Seller.
4. Dispatch service
Service to dispatch a Seller's engineer to investigate, adjust or trial test Seller's Goods is at the Buyer's expense.
5. Disclaimer
 - 1) In our constant efforts to improve, TSUBAKIMOTO CHAIN may make changes to this document or the product described herein without notice.
 - 2) Considerable effort has been made to ensure that the contents of this document are free from technical inaccuracies and errors. However, any such inaccuracies or errors reported will be gladly examined and amended as necessary.



TSUBAKIMOTO CHAIN CO.

1-1, Kohtari-Kuresumi, Nagaokakyo
Kyoto 617- 0833, Japan
Website: <http://tsubakimoto.com/>

Global Associated Partners:

U.S. Tsubaki Power Transmission, LLC
<http://www.ustsubaki.com/>

Tsubakimoto Singapore Pte. Ltd.
<http://tsubaki.sg/>

Tsubakimoto Europe B.V.
<http://tsubaki.eu/>

Tsubaki of Canada Limited
<http://tsubaki.ca/>

Taiwan Tsubakimoto Co.
<http://tsubakimoto.com.tw/>

Tsubakimoto U.K. Ltd.
<http://tsubaki.eu/>

Tsubaki Australia Pty. Limited
<http://tsubaki.com.au/>

Tsubakimoto Chain (Shanghai) Co., Ltd.
<http://tsubaki.cn/>

Tsubakimoto Korea Co., Ltd..
<http://tsubakimoto-tck.co.kr/>